

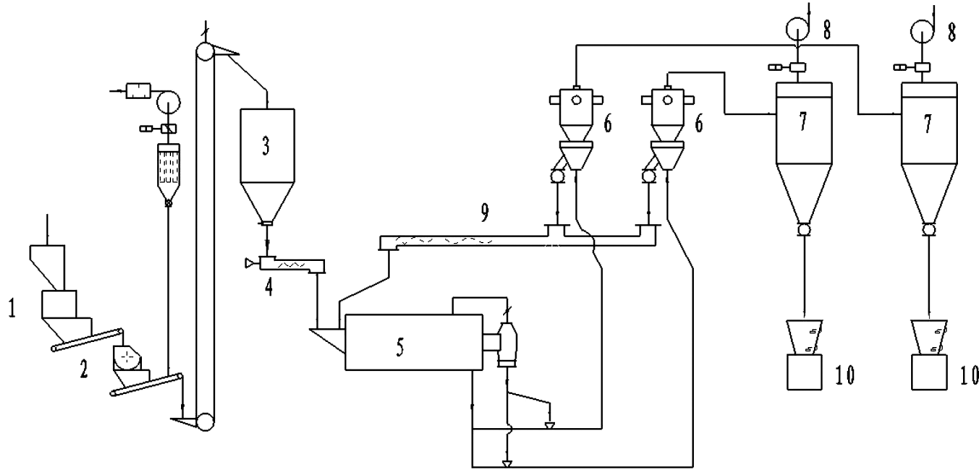

球磨机配卧式分级机生产线

Ball Mill & Horizontal Classifier Production Line



1、鄂破机 (jaw crusher) 2、锤破机 (hammer crusher) 斗提机 (Lifting machine) 3、储料仓 (material store chamber) 4、定量加料 (dosing system) 5、球磨机 (ball mill) 6、分级机 (classifier) 7、除尘器 (dust catcher) 8、引风机 (draft fan) 9、粗料返回 (coarse-particle return) 10、包装 (packing)

简介 (Brief Introduction) :

本工艺是整个流程通过采用除尘器、引风机、气力输送系统的有效组合，以及对各个粉尘点的严格控制，使用高质量过滤材料，保证粉尘排放量小于 40 毫克 / 立方米，投产后可达到 20 毫克 / 立方米。避免了粉尘外溢，整个生产过程负压生产，清洁环保。

The whole process of the technology ensures that the emission of dust is lower than 40 mg / m³ and 20 mg / m³ after production, by adopting the combination of dust collector, draft fan and pneumatic conveying system, the strict control of every dust concentration point, and the use of high-quality filter material. The equipment can prevent dust leak and make the whole technological process negative and clean.

主要特点 (Characteristics):

球磨机: Ball Mill

- ◆ 完全按超细填料级矿物加工要求设计
- ◆ 优化了球磨机的长径比
- ◆ 篦板式磨尾出料，出料顺畅，无涨磨现象，筒体无须冷却
- ◆ 研磨介质按产品要求合理配比，研磨效率高。
- ◆ 优化了驱动器和研磨能耗的匹配，最大限度地节省能耗
- ◆ 和分级机形成封闭系统，负压输送，无粉尘
- ◆ Designed to the standards of ultrafine mineral manufacturing.
- ◆ Optimized length-to-diameter factor of ball mill
- ◆ Grid plate at the end of the ball mill discharges powder fluently, no dilating and no necessary to cool the tube
- ◆ Grinding medium chosen according to customers' product, high filling rate and efficiency

- ◆ Perfect match between drive station and energy consumption of grinding, energy saving to the fullest extent possible.
- ◆ Forming a closed system with classifier, with negative pressure transport, without powder pollution.

应用范围 (Application):

- ◆ 软质材料: 方解石、大理石、石灰石、重晶石、石膏、矿渣等。
- ◆ 硬质材料: 石英、长石、碳化硅、棕刚玉、莫来石、超细水泥、锆英砂等。
- ◆ Soft material: calcite, marble, limestone, barite, gypsum, slag etc.
- ◆ Hard material: quartz, felspa, carborundum, corundum, fine cement etc.

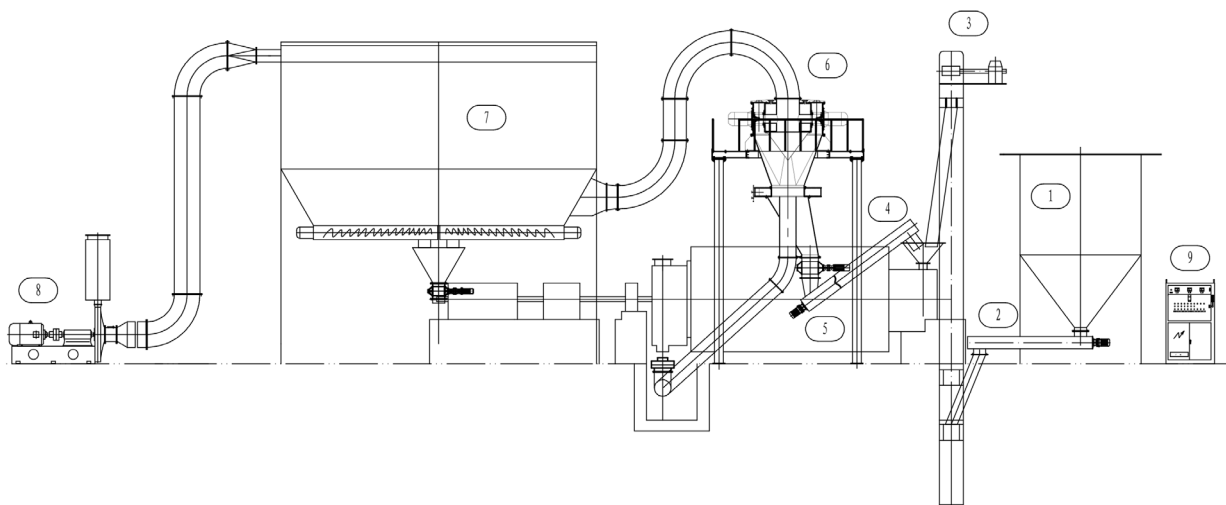

1、料仓 2、计量进料铰刀 3、入料提升机 4、粗料返回铰刀 5、球磨机 6、卧式分级机总成 7、成品收集除尘器 8、系统引风机 9、电控系统

技术参数 (Technical Parameter):

项 目 Item	配置明细								
1250目年产量 (万吨)	0.8	1	1.5	2	2.5	3	4	5	7.8
600目重钙产量 600meshGCC Production capacity (kg/h)	1500	2200	3300	4000	5800	7500	8000	11000	16000
800目重钙产量 800meshGCC Production capacity (kg/h)	1400	1900	2900	3500	5000	6500	7000	9400	14000
1250目重钙产量 1250meshGCC Production capacity (kg/h)	1000	1400	2200	2700	3600	4400	5400	7000	10000
2500目重钙产量 2500meshGCC Production capacity (kg/h)	450	580	880	1100	1400	1760	2200	2800	3520-4400
球磨机型号 Ball mill model (直径mX长度m)	Φ1.5X5	Φ1.83X4.5	Φ1.83X6	Φ2.2X4	Φ2.2X6 或 Φ2.4X6	Φ2.6X6	Φ2.8X6	Φ2.8X8 或 Φ3X6	Φ3X8
球磨机功率 Power of the ball mill (kW)	110	160	220	250	355 或 450	560	630	800 或 900	1000
分级机型号 Classifier model	HFW500 or HFW3315	HFW4315	HFW4400 or HFW6315 or 2HFW3315	HFW3500	HFW4500 or HFW6400 or 2HFW3400	2HFW6315 or 2HFW4400	HFW6500 or 2HFW3500	2HFW4500 or 2HFW6400	2HFW6500
生产线总功率 General power of the whole production line (kW)	≤ 300	≤ 380	≤ 550	≤ 700	≤ 900	≤ 1130	≤ 1450	≤ 1850	≤ 2520
除尘器过滤面积 Fliter area (m ²)	120	160	250		400	500	600	800	1200
粉尘浓度 Thickness of dust	≤ 20mg/m ³								

注: 1、以上参数是以加工 1250 目重钙为例 (All of the parameters above are according to 1250 mesh GCC)。

2、由于各地物料有所不同, 以上参数仅供参考 (As different material from different places, the parameter is just for your reference)。